



INVERTER SERIES HIGH PERFORMANCE VECTOR CONTROL A1000



EN
DE
ES
FR
IT

A1000
A1000
A1000
A1000

A1000

YASKAWA A1000 HIGH PERFORMANCE DRIVE

Contents

- ▶ **Page 2**
Experience & Innovation
A leader in Inverter Drives technology
Main Features
- ▶ **Page 3**
Customize Your Drive
- ▶ **Page 4/5**
Permanent Magnet Motor Control
- ▶ **Page 6/7**
Safety Features & Communication
- ▶ **Page 8/9**
Easy start-up and reliable operation
- ▶ **Page 10/11**
Drive Design & Features
- ▶ **Page 12**
Efficiency & Environment
- ▶ **Page 13**
Specifications
- ▶ **Page 14**
Connection Diagram
- ▶ **Page 15**
Terminal Functions
- ▶ **Page 16/17**
Dimensions
- ▶ **Page 18**
Options
- ▶ **Page 19**
Ratings & Type Descriptions

Experience & Innovation

For more than 90 years YASKAWA has been manufacturing and supplying mechatronic products for machine building and industrial automation. Its standard products as well as tailor-made solutions are famous and have a high reputation for outstanding quality and durability.

A leader in Inverter Drives technology

Extensive research and development has allowed YASKAWA to remain at the forefront of motion control and automation technology. This technological leadership has helped to modernise industries such as mining, steel, pulp and paper, chemical, automotive, packaging, machine tool and semiconductor.

In 2007 YASKAWA produced its 10 millionth inverter in the new inverter plant in Yukuhashi, Japan. By this YASKAWA is probably the biggest inverter manufacturer in the world.

With the new A1000, YASKAWA continues its tradition of developing innovative solutions in drive technology. The A1000 provides remarkable advantages through excellent motor drive performance, environmental benefits and energy savings as well as many user orientated operational features. Moreover, the A1000 offers advanced characteristics that are included as standard.

In response to the needs of users, we have introduced next-generation product features to A1000 vector control technology:

Main Features:

- ▶ **For Induction Motor and Permanent Magnet Motor Control:**
The A1000 is a premium inverter drive for a wide field of applications including great advantages in more than one way
- ▶ **Providing newest Safety Features:**
Safety features of the A1000 comply with today's market safety requirements and standards
- ▶ **For Easy Start-up and Reliable Operation:**
YASKAWA A1000 provides significant costs reduction potentials during installation and operation
- ▶ **Improved Drive Design & Functions:**
Small size and application oriented design improve performance, reliability and performance life
- ▶ **Enhanced Efficiency & Environment:**
Using the A1000 saves energy and reduces audible noise

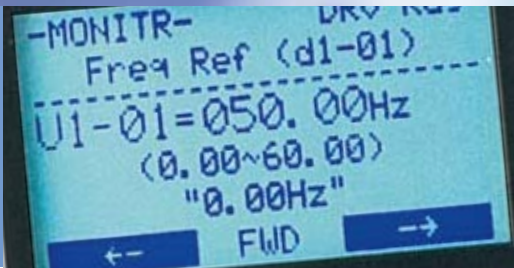

Permanent Magnet Motor Control

- ▶ Open loop position control (No Motor Feedback)
- ▶ 200% rated torque at 0 rpm
- ▶ New Auto-Tuning Features
- ▶ Tuning of the Speed Loop according to Load
- ▶ Power Loss Recovery

Safety Features & Communication

- ▶ Safety Torque Off (STO) according to EN954-1 safety category 3, stop category 0; EN ISO 13849-1 PLd; IEC EN 61508 SiL2
- ▶ External Device Monitor (EDM) to Observe the Safety Status

Easy Start-up & Reliable Operation

- ▶ Application Parameter Presets
- ▶ Screwless Removable Control Terminal with Parameter Backup
- ▶ Online Auto-Tuning for Motor Parameter
- ▶ Tuning of the Speed Loop according to Load
- ▶ Parameter Copy and Backup Function
- ▶ Engineering Tool DriveWizard Plus for Parameter Management
- ▶ Application SW Library
- ▶ Performance Life Diagnostics for all major inverter components

Drive Design & Functions

- ▶ Even more compact
- ▶ Side-by-Side Mounting
- ▶ Dual Rating for Cost & Space Saving
- ▶ Long Performance Life
- ▶ Overexcitation Braking to reduce Deceleration Time

Efficiency & Environment

- ▶ Advanced Energy Saving Functionality
- ▶ Unique PWM function reduces audible noise.
- ▶ Minimum Power Loss in Normal Duty Rating

Customize Your Drive

- ▶ DriveWorksEZ visual programming tool. Simply drag and drop icons to customize your drive. Create special sequences and detection functions, then load them onto the drive.

Program a customized sequence

- ▶ Example: Sensorless positioning control function (Available soon)

Create customized detection features

- ▶ Example: Machine weakening analysis using torque pulse detection

USB port lets the drive connect to a PC

- ▶ Example: Sensorless positioning control function (Available soon)

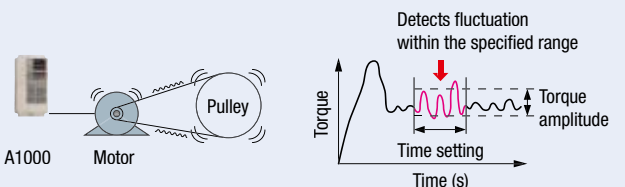
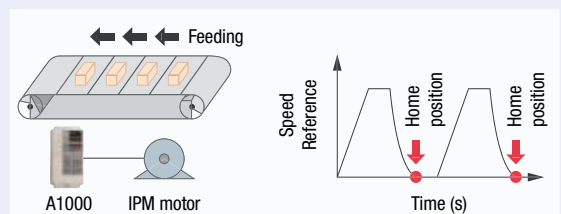

Note: Drives are also equipped with an RJ-45 comm. port that takes the existing WW103 cable used in Yaskawa's previous models. Simply remove the operator keypad for to the RJ-45 connector.



Advanced Motor Control

Advanced Drive Technology

- ▶ Capable of driving different types of motor. A1000 runs not only induction motors, but also synchronous motors like IPM*¹ and SPM*² motors with high performance open and closed loop vector control.
- ▶ Minimize equipment needed for your business by using the same drive to run induction and synchronous motors.

*1 Interior Permanent Magnet Motor
(Motors with permanent magnets inserted into the rotor)
*2 Surface Mounted Permanent Magnet Motor
(Motors with permanent magnets mounted on the surface of the rotor)

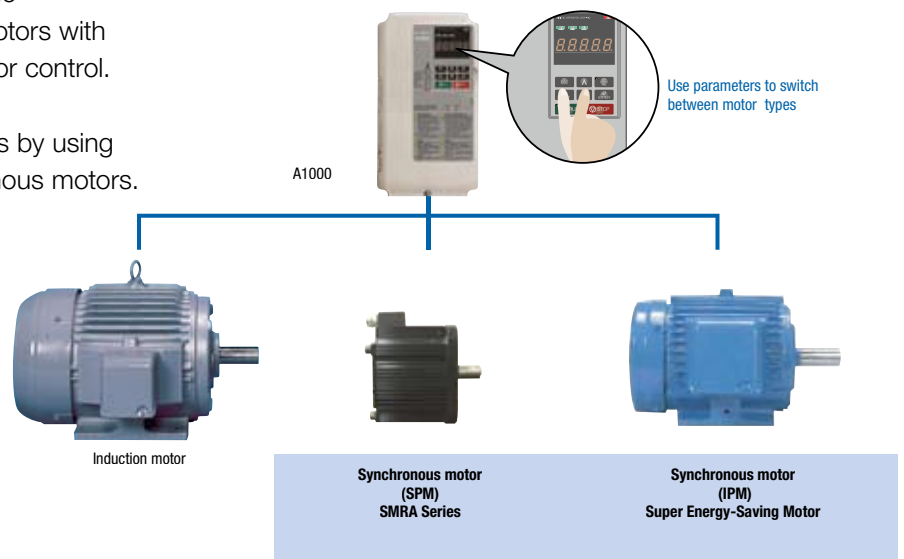

Positioning Capability without External Devices

- ▶ Use an IPM motor to perform position control – without motor feedback. Electrical saliency in IPM motors makes it possible to detect speed, direction and rotor position without the use of external feedback devices.
- ▶ Positioning functionality without a PLC. Visual programming in DriveWorksEZ eliminates the need for external controllers by giving the user the power to create customized functions such as position control.

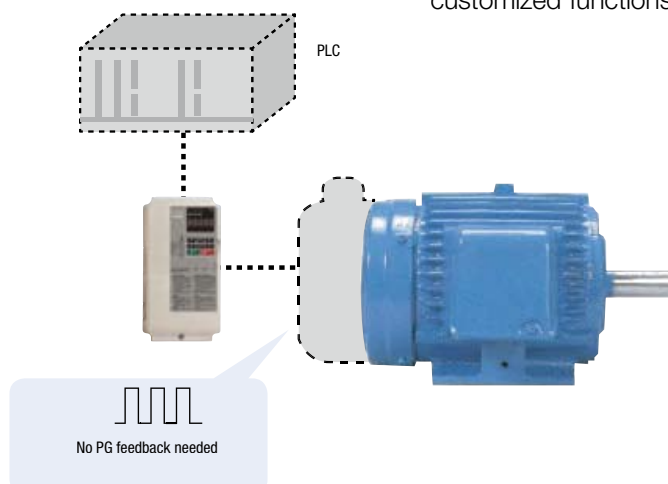



New Auto-Tuning Features

- ▶ Auto-Tuning features optimize drive parameters for operation with induction motors as well as synchronous motors to achieve the highest performance levels possible.
- ▶ Optimizing not only the drive and motor performance, but also automatically adjusts settings relative to the connected machinery.
- ▶ New Auto-Tuning methods.
A1000 continuously analyzes changes in motor characteristics during operation for highly precise speed control.

Tuning the Motor	
Rotational Auto-Tuning	Applications requiring high starting torque, high speed, and high accuracy.
Stationary Auto-Tuning	Applications where the motor must remain connected to the load during the tuning process.
Line-to-Line Resistance Auto-Tuning	For tuning after the cable length between the motor and drive has changed, or when motor and drive capacity ratings differ.
Energy-Saving Auto-Tuning	For running the motor at top efficiency all the time.

Tuning the Load	
ASR* Tuning	Perfects responsiveness relative to the machine. Until now, this tuning procedure was fairly time consuming to set.
Inertia Tuning	Optimizes the drive's ability to decelerate the load. Useful for applications using Kinetic Energy Buffering Function and Feed Forward functions.

* Automatic Speed Regulator

Powerful Torque Characteristics

- ▶ Powerful torque at 0 Hz, without sensors or feedback devices.
Until recently, sensorless control has been out of reach for synchronous motors. Now A1000 provides powerful starting torque algorithm without relying on pole sensors or motor feedback.
- ▶ High-performance current vector control achieves powerful starting torque with an induction motor.

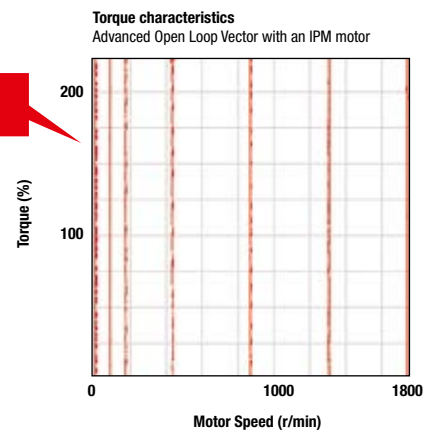

Synchronous Motor	
Advanced Open Loop Vector for PM motors	200% rated torque at 0 r/min*, speed range of 1:100*
Closed Loop Vector Control for PM motors	200% rated torque at 0 r/min, speed range of 1:1500

* only IPM motor

Induction Motor	
Open Loop Vector Control	200% rated torque at 0.3 Hz*, speed range of 1:200
Closed Loop Vector Control	200% rated torque at 0 r/min*, speed range of 1:1500

* Proper output torque depends on matching drive and motor capacity.

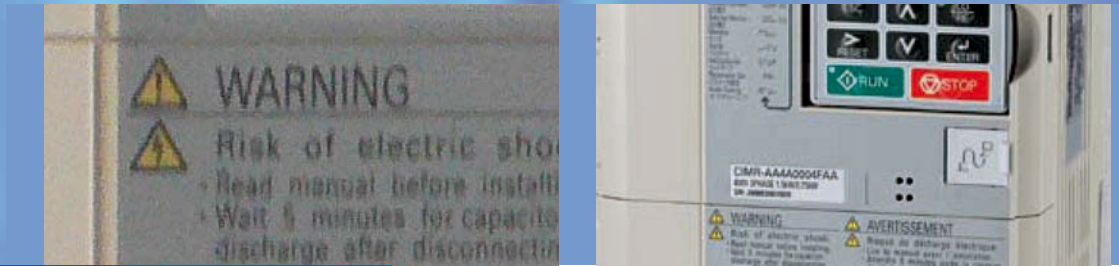

Safety Features & Communication

Power Loss & Recovery

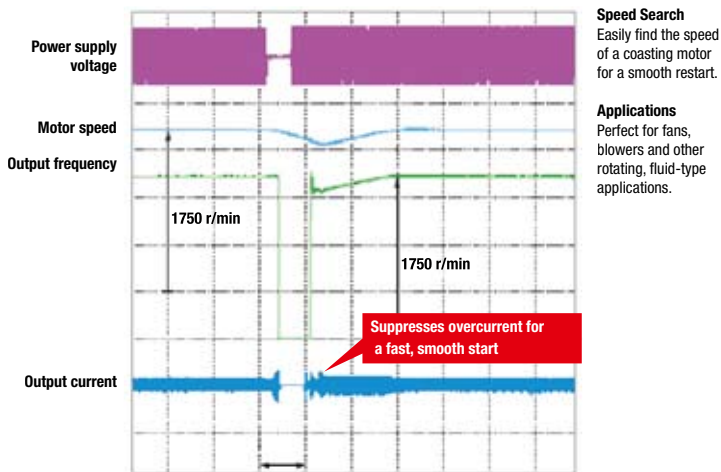

- ▶ A1000 offers two ways to handle momentary power loss
- ▶ A1000 is capable of handling momentary power loss with sensorless control for induction motors as well as for synchronous motors.
- ▶ A1000 lets you ride through a power loss for up to 2 seconds.*

* Option available for certain models.

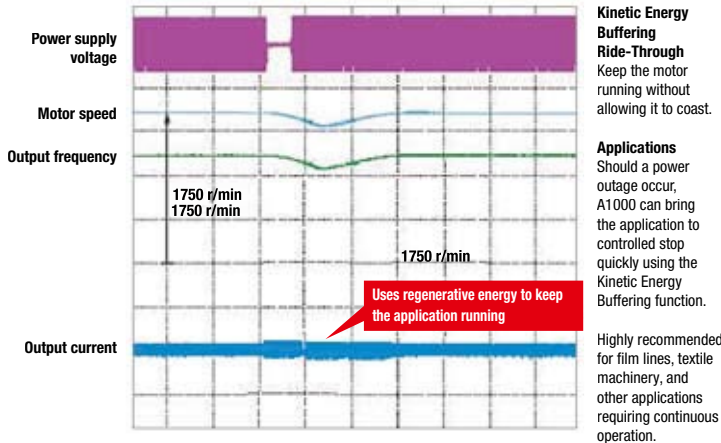

Note: Separate sensor to detect power loss are required.

Protective Design

A variety of protective designs are available to reinforce the drive against moisture, dust, oil mist, vibration, corrosive sulfur gas, conductive particles, and other harsh environments.

- ▶ IP54, dust proof and splash-waterproof options are also available
- ▶ RoHS Compliance



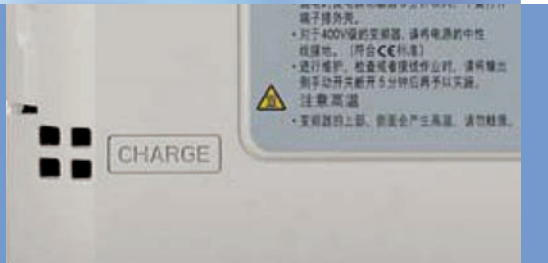

Safety Features as a Standard

- ▶ A1000 provides Safe Torque Off (STO) functional safety in compliance with EN954-1 safety category 3 stop category 0, EN ISO 13849-1, PLd, IEC/EN61508 SIL2.
- ▶ An External Device Monitor (EDM) function has also been added to monitor the safety status of the drive.

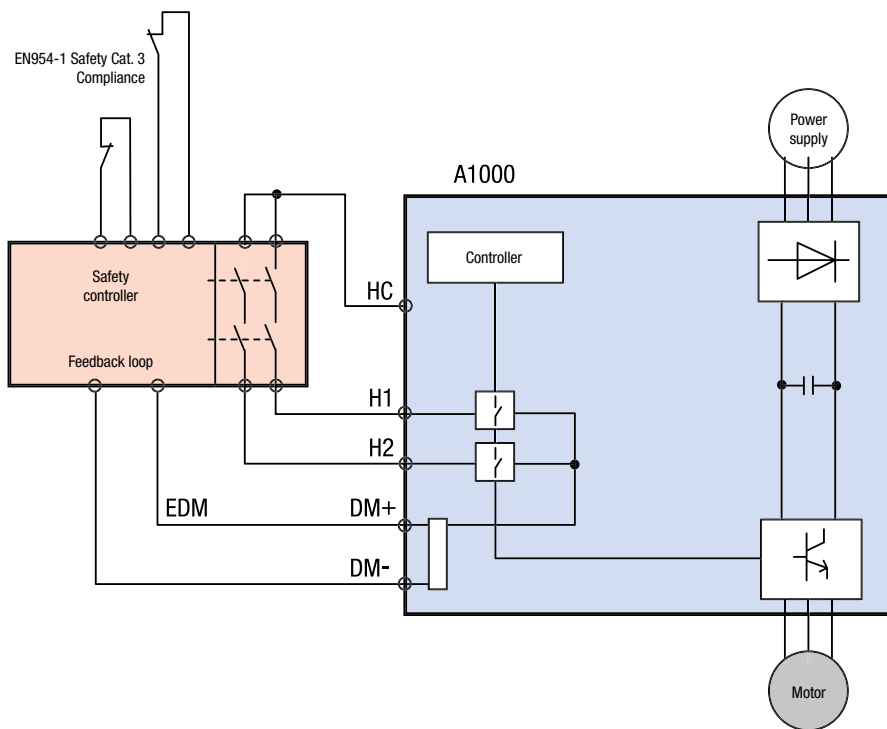

All Major Serial Communication Protocols

- ▶ RS-422/485 (MEMOBUS/Modbus at 115.2 kbps) standard on all models.
- ▶ Option cards available for all major fieldbuses used across the globe:





Easy start-up and reliable operation

Application Parameter Presets

- ▶ A1000 automatically sets parameters needed for major applications. Selecting the appropriate application optimizes the drive for top performance, while saving time for set up.

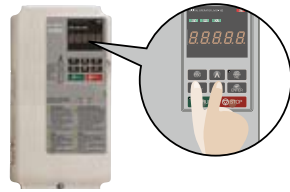
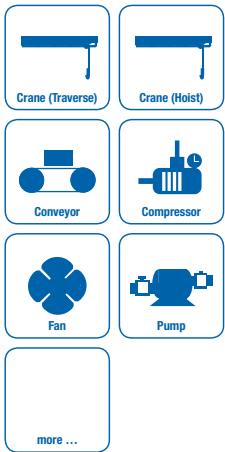

Setting	Setting
00	General-purpose
01	Water Supply Pump
02	Conveyor
03	Exhaust Fan
04	HVAC Fan
05	Air Compressor
06	Crane (Hoist)
07	Crane (Traverse)

Parameters are programmed automatically	
A1-02	Control mode selection
C1-01	Accel Time 1
C1-02	Decel Time
C6-01	ND/HD Selection

Example using Application Presets
Selecting "Conveyor" optimizes parameter settings so the drive is ready to start your conveyor application immediately

Multifunction Terminal Block

- ▶ The first terminal board with a Parameter Backup Function
The terminal block's ability to save parameter setting data makes it easy to get the application back online in the event of a failure requiring drive replacement.

A1000 Terminal Block



Parameter		
Name	Number	Setting
ND/HD	C6-01	1
Control Mode	A1-02	0
Frequency Reference Selection	b1-01	1
Run Command Selection	b1-02	1



Parameter Copy Function

- ▶ All standard models are equipped with a Parameter Copy Function that allows parameter settings to be easily copied from the drive or uploaded for quick setup using the operator.
- ▶ A USB Copy Unit is also available as an even faster, more convenient way to back up settings and instantly program the drive.



Engineering Tool DriveWizard Plus

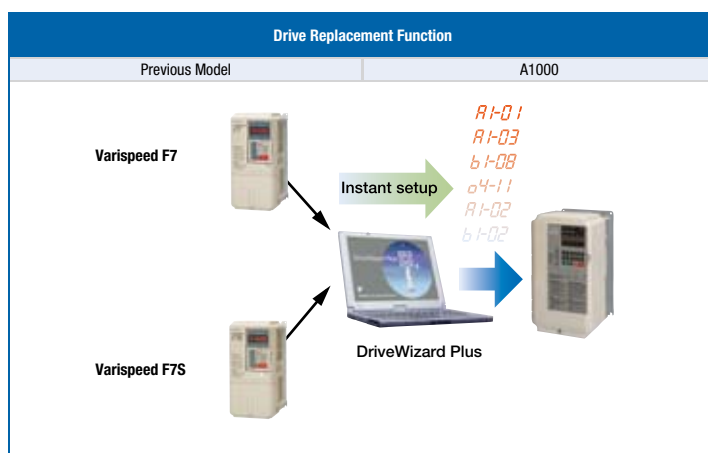

Note: To obtain a copy of DriveWizard Plus, contact a Yaskawa representative.

- ▶ Engineering Tool DriveWizard Plus
- ▶ Manage the unique settings for all your drives right on your PC.
- ▶ An indispensable tool for drive setup and maintenance. Edit parameters, access all monitors, create customized operation sequences, and observe drive performance with the oscilloscope function.
- ▶ The Drive Replacement feature in DriveWizard Plus saves valuable time during equipment replacement and application upgrades by converting previous Yaskawa product parameter values to the new A1000 parameters automatically.



Drive Design & Features

Even More Compact

- ▶ Yaskawa continues to make applications even smaller by combining the compact designed drive with the light, efficient design of a synchronous motor.
- ▶ Use Side-by-Side installation for an even more compact setup.
- ▶ Finless models available*.

* Coming soon

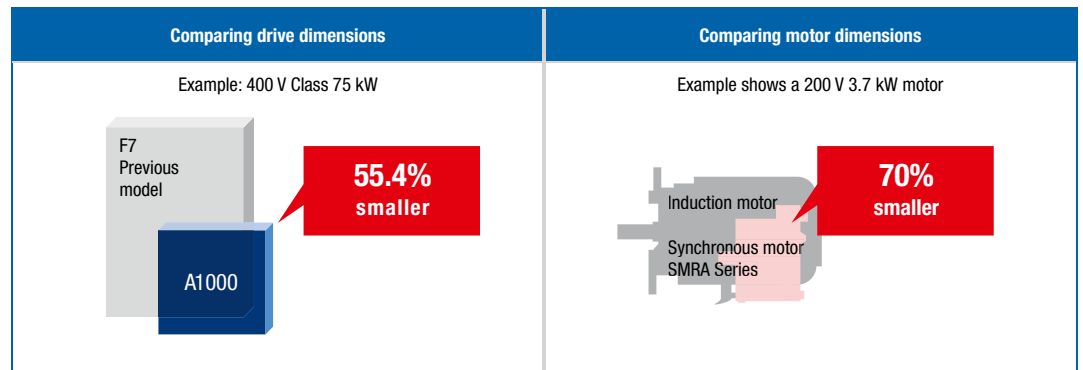

Dual Rating for Cost & Space Saving

- ▶ Each drive lets the user choose between Normal Duty or Heavy Duty operation. Depending on the application, A1000 can run a motor an entire frame size larger than our previous model.

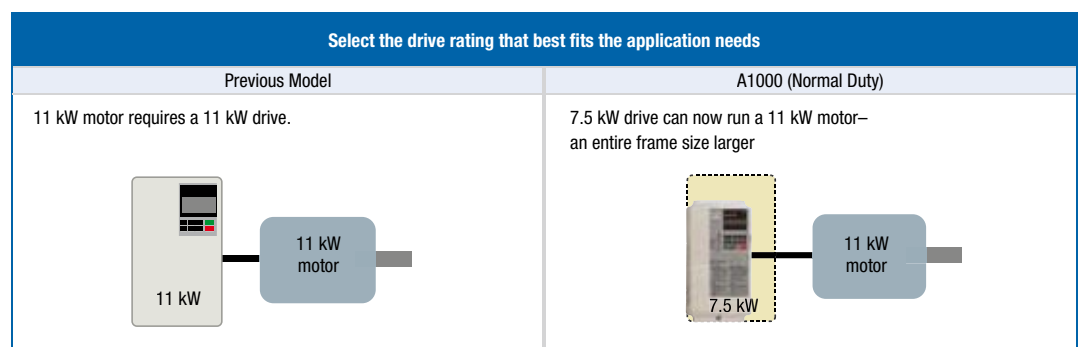

Dual Ratings in A1000

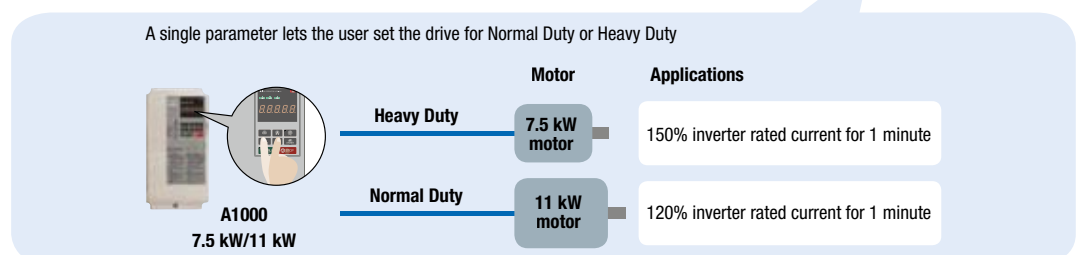

Note: Always select a drive with a current rating greater than the motor rated current.



Long Performance Life

- ▶ Designed for 10 years of maintenance-free operation. Cooling fan, capacitors, relays, and IGBTs have been carefully selected and designed for a life expectancy up to ten years.*



* Assumes the drive is running continuously for 24 hours a day at 80% load with an ambient temperature of 40°C.

Performance Life Monitors

- ▶ Yaskawa's latest drive series is equipped with performance life monitors that notify the user of part wear and maintenance periods to prevent problems before they occur.

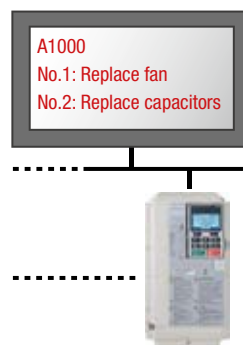

Operator Display	Corresponding Component
LT-1	Cooling fan
LT-2	Capacitors
LT-3	Inrush prevention relay
LT-4	IGBTs

Drive outputs a signal to the control device indicating components may need to be replaced

Variety of Braking Functions

- ▶ Overexcitation deceleration capabilities bring the motor to a quick stop without the use of a braking resistor.
- ▶ All models up to 30 kW (HD) are equipped with a braking transistor for even more powerful braking options by just adding a braking resistor.

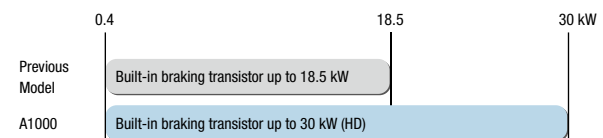

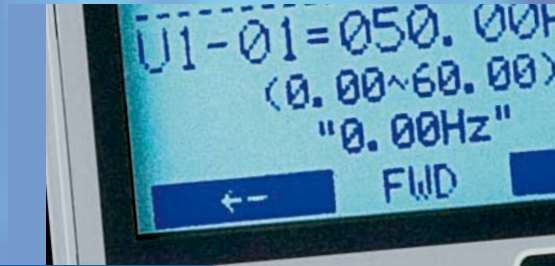

Efficiency & Environment

Energy Saving

- ▶ Loaded with advanced energy-saving control technology. Energy-Saving control makes highly efficient operation possible with an induction motor.
- ▶ Amazing energy saving with a synchronous motor. Combining the high efficiency of a synchronous motor along with A1000's Energy-Saving control capabilities allows for unparalleled energy saving.

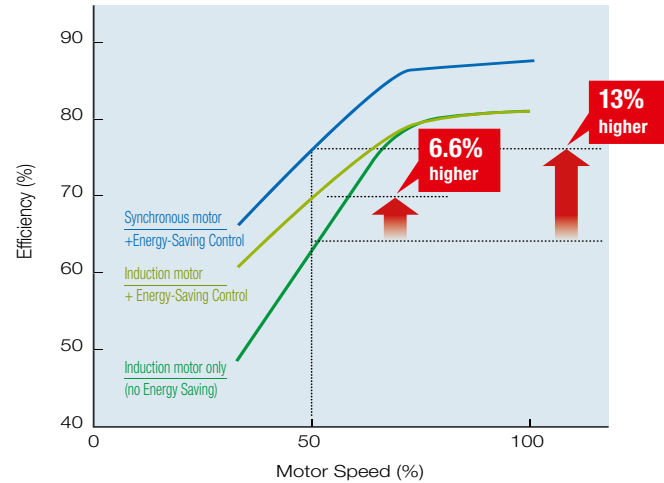

Conditions:
Annual energy savings for an HVAC fan application running 100 3.7 kW motors. Electric costs of 8 cents/kWh*, Average industrial electric costs in Europe

Examples of energy saving with A1000 and PM Motor		
	Power consumption	Electrical costs
A Induction motor + A1000	1,903,100 kWh	€ 152,300
B IPM motor + A1000	1,754,600 kWh	€ 140,400
Annual savings on energy costs: [A] vs. [B]	148,500 kWh	€ 11,900
Annual reduction in CO ₂	$148,500 \text{ kWh} \times 0.555 \div 1,000 =$	82.4 tons!
	Assumes 1 kW of power consumed creates 0.555 kg/kWh of CO ₂	

Total Energy Savings
€11,900

Efficiency with energy saving function
Example shows a 200 V 4.0 kW drive in a fan or pump application

Noise Reduction

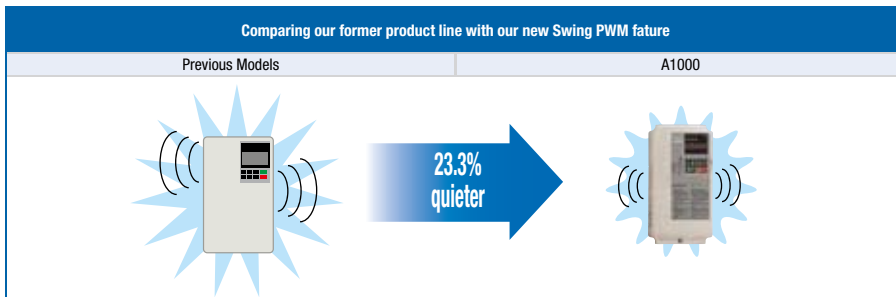

Note:
Calculated by comparing peak values during noise generation

- ▶ A1000 uses YASKAWA Swing PWM function to suppress electromagnetic and audible motor noise, creating a more peaceful environment.



Standard Specifications

Item	Specifications	
Control Characteristics	Control Method	V/f Control, V/f Control with PG, Open Loop Vector Control, Closed Loop Vector Control, Open Loop Vector for PM, Closed Loop Vector for PM, Advanced Open Loop Vector for PM
	Frequency Control Range	0.01 to 400 Hz
	Frequency Accuracy (Temperature Fluctuation)	Digital reference: within ±0.01% of the max. output frequency (-10 to +40°C) Analog reference: within ±0.1% of the max. output frequency (25°C ±10°C)
	Frequency Setting Resolution	Digital referece: 0.01 Hz Analog referece: 0.03 Hz / 60 Hz (11 bit)
	Output Frequency Resolution	0.001 Hz
	Frequency Setting Signal	-10 to +10 V, 0 to +10 V, 4 to 20 mA, Pulse Train
	Starting Torque	150%/3 Hz (V/f Control and V/f Control with PG), 200%/0.3 Hz*1 (Open Loop Vector Control), 200%/0 r/min ⁻¹ (Closed Loop Vector Control, Closed Loop Vector Control for PM, and Advanced Open Loop Vector Control for PM), 100%/5% speed (Open Loop Vector Control for PM)
	Speed Control Range	1:1500 (Closed Loop Vector Control and Closed Loop Vector for PM) 1:200 (Open Loop Vector Control) 1:40 (V/f Control and V/f Control with PG) 1:20 (Open Loop Vector for PM) 1:100 (Advanced Open Loop Vector for PM)
	Speed Control Accuracy	±0.2% in Open Loop Vector Control (25°C ±10°C) ² , 0.02% in Closed Loop Vector Control (25°C ±10°C)
	Speed Response	10 Hz in Open Loop Vector (25°C ±10°C), 50 Hz in Closed Loop Vector Control (25°C ±10°C) (excludes temperature fluctuation when performing Rotational Auto-Tuning)
	Torque Limit	All Vector Control allows separate settings in four quadrants
	Accel/Decel Time	0.00 to 6000.0 s (4 selectable combinations of independent acceleration and deceleration settings)
	Braking Torque	Drives of 200/400 V 30 kW or less have a built-in braking transistor. 1. Short-time decel torque ³ : over 100% for 0.4/ 0.75 kW motors, over 50% for 1.5 kW motors, and over 20% for 2.2 kW and above motors (over excitation braking/High-Slip Braking: approx. 40%) 2. Continuous regen. torque: approx. 20% (approx. 125% with dynamic braking resistor option ⁴ : 10% ED, 10s, internal braking transistor)
	V/f Characteristics	User-selected programs and V/f preset patterns possible
Main Control Functions	Torque control, Droop control, Speed/torque control switching, Feedforward control, Zero-servo control, Momentary power loss ride-thru, Speed search, Overtorque detection, Torque limit, 17-step speed (max), Accel/decel time switch, S-curve accel/decel, 3-wire sequence, Auto-tuning (rotational, stationary), Online tuning, Dwell, Cooling fan on/off switch, Slip compensation, Torque compensation, Frequency jump, Upper/lower limits for frequency reference, DC injection braking at start and stop, Overexcitation braking, High slip braking, PID control (with sleep function), Energy saving control, MEMOBUS comm. (RS-485/422 max, 115.2 kbps), Fault restart, Application presets, DriveWorksEZ (customized function), Removable terminal block with parameter backup function...	
Protection Function	Motor Protection	Motor overheat protection based on output current
	Momentary Overcurrent Protection	Drive stops when output current exceeds 200% of Heavy Duty Rating
	Overload Protection	Drive stops after 60 s at 150% of rated output current (Heavy Duty Rating) ⁵
	Overvoltage Protection	200 V class: Stops when DC bus exceeds approx. 410 V, 400 V class: Stops when DC bus exceeds approx. 820 V
	Undervoltage Protection	200 V class: Stops when DC bus exceeds approx. 190 V, 400 V class: Stops when DC bus exceeds approx. 380 V
	Momentary Power Loss Ride-Thru	Immediately stop after 15 ms or longer power loss. Continuous operation during power loss of less than 2 s (standard) ⁶
	Heatsink Overheat Protection	Thermistor
	Braking Resistance Overheat Protection	Overheat sensor for braking resistor (optional ERF-type, 3% ED)
	Stall Prevention	Stall prevention during acceleration/deceleration and constant speed operation
	Ground Protection	Protection by electronic circuit ⁷
Operating Environment	Charge LED	Charge LED remains lit until DC bus has fallen below approx. 50 V
	Area of Use	Indoors
	Ambient Temperature	-10 to +50°C (open chassis), -10 to +40°C (NEMA Type 1)
	Humidity	95% RH or less (no condensation)
	Storage Temperature	-20 to +60°C (short-term temperature during transportation)
	Altitude	Up to 1000 meters (output derating of 1% per 100 m above 1000 m, max. 3000 m)
	Shock	10 to 20 Hz: 9.8m/s ² ; 20 to 55 Hz: 5.9 m/s ² for 200 V up to 45 kW and 400 V up to 75 kW, 2.0 m/s ² for 200 V, 55 to 110 kW and 400 V, 90 to 315 kW
	Safety Standard	EN954-1 safe category 3 stop category 0; EN ISO 13849-1; IEC EN 61508 SIL2
Protection Design	IP00 open-chassis, IP20, NEMA Type 1 enclosure	

*1: Requires a drive with recommended capacity.

*2: Speed control accuracy may vary slightly depending on installation conditions or motor used. Contact Yaskawa for details.

*3: Instantaneous average deceleration torque refers to the torque required to decelerate the motor (uncoupled from the load) from the rated motor speed down to zero in the shortest time.

*4: If L3-04 is enabled when using a braking resistor or braking resistor unit, the motor may not stop within the specified deceleration time.

*5: Overload protection may be triggered at lower levels if output frequency is below 6 Hz.

*6: Varies in accordance with drive capacity and load. Drives with a capacity of smaller than 11 kW in the 200 V (model: CIMR-AC2A0056) or 400 V (model: CIMR-AC4A0031) require a separate Momentary Power Loss Recovery Unit to continue operating during a momentary power loss of 2 s or longer.

*7: Ground protection cannot be provided when the impedance of the ground fault path is too low, or when the drive is powered up while a ground fault is present at the output.



Connection Diagram

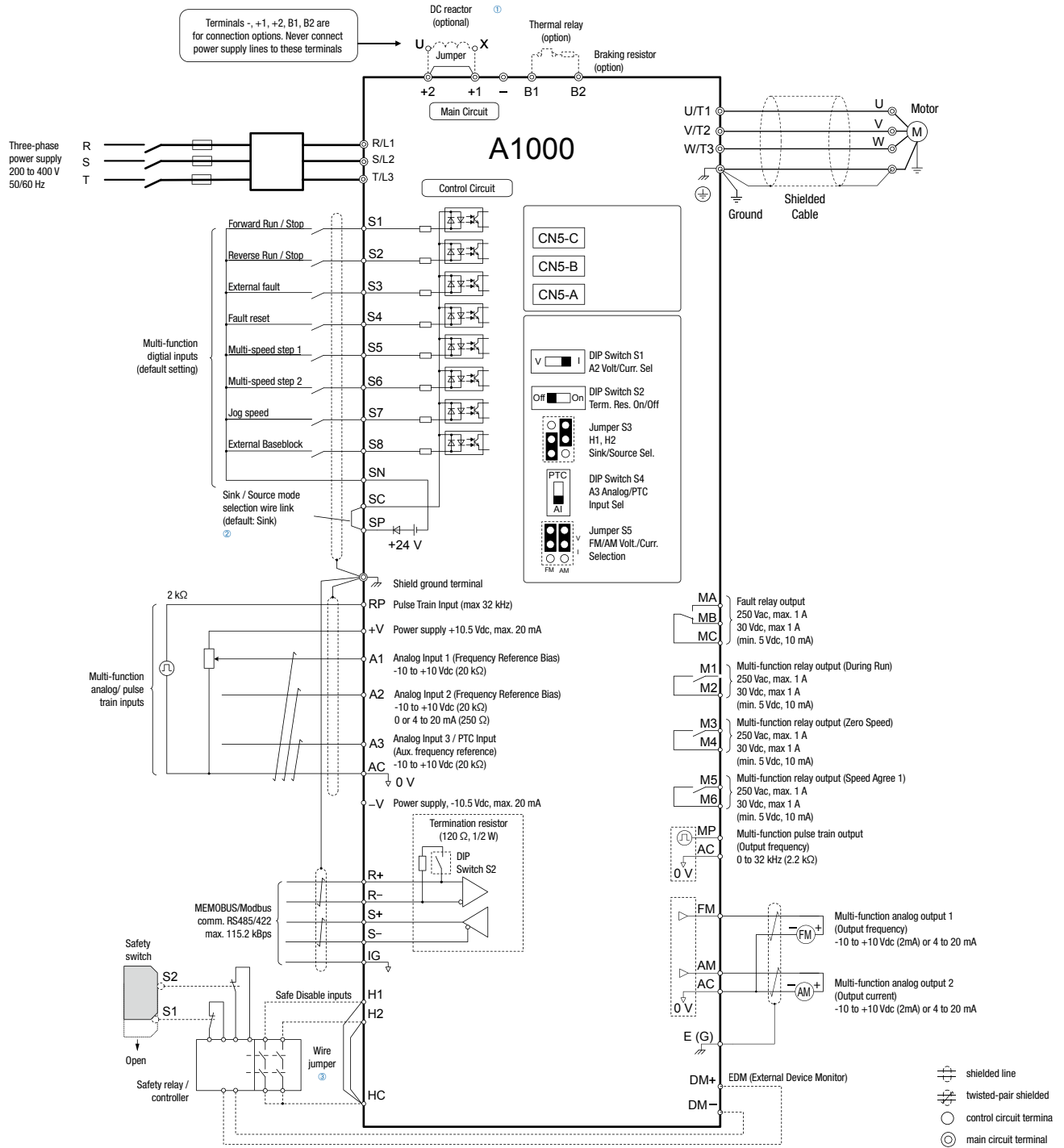

A1000

Terminal Functions

Main Circuit Terminals

Voltage	200 V			400 V		
Model CIMR-AA2A □□□□	2A0004 to 2A0081	2A0110, 2A0138	2A0169, 2A0211	4A0002 to 4A0044	4A0058, 4A0072	4A0088 to 4A0165
Max. Applicable Motor Capacity*1 kW	0.4 to 18.5	22, 30	37, 45	0.4, 18.5	22, 30	37 to 75
R/L1	Main circuit input power supply			Main circuit input power supply		
S/L2						
T/L3						
U/T1	Drive output			Drive output		
V/T2						
W/T3						
B1	Braking resistor unit		-	Braking resistor unit		-
B2						
(-)						
(+1)	DC reactor (Ⓟ1-Ⓟ2) DC power supply (Ⓟ1-Ⓟ)*2		DC power supply (Ⓟ1-Ⓟ)*2 Braking unit (Ⓟ3-Ⓟ)	DC reactor (Ⓟ1-Ⓟ2) DC power supply (Ⓟ1-Ⓟ)*2		DC power supply (Ⓟ1-Ⓟ)*2 Braking unit (Ⓟ3-Ⓟ)
(+2)						
(+3)						
Ⓟ	Ground terminal (100 Ω or less)			Ground terminal (10 Ω or less)		

*1: Max. Applicable Motor Capacity indicates Heavy Duty *2: DC power supply input terminals (+1, -) are not UL/cUL and CE certified. Note: A dash, (-), indicates no applicable terminals.

Control Circuit Terminals (200 V/400 V Class)

Type	Terminal	Terminal Name (Function)	Function (Signal Level) Default Setting
Safe Disable Inputs	H1	Safe Disable input 1	24 Vdc, 8 mA One or both open: Drive output disabled; Both closed: Normal operation; Internal impedance: 3.3 kΩ; Off time of at least 1 ms;
	H2	Safe Disable input 2	Disconnect the wire jumpers shorting terminals H1, H2, and HC to use the Safe Disable inputs. Set the S3 jumper to select between sinking, sourcing mode, and the power supply.
	HC	Safe Disable function common	Safe disable function common
Analog Inputs / Pulse Train Input	RP	Multi-function pulse train input (Frequency reference)	Input frequency range: 0 to 32 kHz; Signal Duty Cycle: 30 to 70%; High level: 3.5 to 13.2 Vdc, low level: 0.0 to 0.8 Vdc; Input impedance: 3 kΩ
	+V	Power supply for analog inputs	10.5 Vdc (max allowable current 20 mA)
	-V	Power supply for analog inputs	-10.5 Vdc (max allowable current 20 mA)
	A1	Multi-function analog input 1 (Frequency reference bias)	-10 to 10 Vdc, 0 to 10 Vdc (input impedance: 20 kΩ)
	A2	Multi-function analog input 2 (Frequency reference bias)	-10 to 10 Vdc, 0 to 10 Vdc (input impedance: 20 kΩ) 4 to 20 mA, 0 to 20 mA (input impedance: 250 Ω) Voltage or current input must be selected by DIP switch S1 and H3-09
	A3	Multi-function analog input 3 / PTC Input (Auxiliary frequency reference)	-10 to 10 Vdc, 0 to 10 Vdc (input impedance: 20 kΩ); Use switch S4 on the control terminal board to select between analog input or PTC input. If PTC is selected, set H3-06 = E.
	AC	Frequency reference common	0 V
Multi-Function Digital Inputs	E(G)	Ground for shielded lines and option cards	-
	S1	Multi-function input 1 (Closed: Forward Run, Open: Stop)	Photocoupler 24 Vdc, 8 mA; Set the wire jumper between SC and SN or SC and SP for selection of sinking/sourcing mode and power supply.
	S2	Multi-function input 2 (Closed: Reverse Run, Open: Stop)	
	S3	Multi-function input 3 (External fault, N.O.)	
	S4	Multi-function input 4 (Fault Reset)	
	S5	Multi-function input 5 (Multi-step speed reference 1)	
	S6	Multi-function input 6 (Multi-step speed reference 2)	
	S7	Multi-function input 7 (Jog reference)	
	S8	Multi-function input 8 (External baseblock)	
	SC	Multi-function input common	
SN	Digital input power supply 0 V	24 Vdc power supply for digital inputs, 150 mA max. Never short terminals SP and SN as doing so will damage the drive.	
Fault Relay	SP	Digital input power supply +24Vdc	
	MA	N.O.	Dry contact, contact capacity
	MB	N.C. output	30 Vdc, 10 mA to 1 A; 250 Vac, 10 mA to 1 A
Multi-Function Digital Output	MC	Fault output common	Minimum load: 5 Vdc, 10 mA
	M1	Multi-function digital output (During run)	Dry contact, contact capacity 30 Vdc, 10 mA to 1 A; 250 Vac, 10 mA to 1 A Minimum load: 5 Vdc, 10 mA
	M2	Multi-function digital output (Zero speed)	
	M3	Multi-function digital output (Zero speed)	
	M4	Multi-function digital output (Zero speed)	
	M5	Multi-function digital output (Speed agree 1)	
M6	Multi-function digital output (Speed agree 1)		
Monitor Output	MP	Pulse train output (Output frequency)	32 kHz (max)
	FM	Analog monitor output 1 (Output frequency)	
	AM	Analog monitor output 2 (Output current)	-10 to +10 Vdc, 0 to +10 Vdc, or 4 to 20 mA Use jumper S5 on the control terminal board to select between voltage or current output at terminals AM and FM. Set parameters H4-07 and H4-08 accordingly when changing the jumper setting.
Safety monitor output	AC	Monitor common	
	DM+	Safety monitor output	Outputs status of Safe Disable function. Closed when both Safe Disable channels are closed. Up to +48 Vdc 50 mA
	DM-	Safety monitor output common	

* Sequence Input changes in accordance with the sinking mode/source mode selection.

Serial Communication Terminals (200 V/400 V Class)

Classification	Terminal	Signal Function	Description	Signal Level
RS-485/422 Transmission	R+	MEMOBUS communications Read	When using RS-422 two wires communication, short-circuit between R+ and S+, R- and S-.	Differential input
	R-	MEMOBUS communications Read		PHC isolation
	S+	MEMOBUS communications send		Differential output
	S-	MEMOBUS communications send		PHC isolation
	IG	Communications output	-	-



Dimensions

Enclosures

Enclosures of standard products vary depending on the model. Refer to the table below.

		200 V Class																			
Model CIMR-AC2A □□□□		0004	0006	0008	0010	0012	0018	0021	0030	0040	0056	0069	0081	0110	0138	0169	0211	0250	0312	0360	0415
Max. Applicable Motor Capacity [kW]	Normal Duty	0.75	1.1	1.5	2.2	3	4.0	5.5	7.5	11	15	18.5	22	30	37	45	55	75	90	110	110
	Heavy Duty	0.4	0.75	1.1	1.5	2.2	3	4.0	5.5	7.5	11	15	18.5	22	30	37	45	55	75	90	110
Enclosure Panel [NEMA Type1]		Standard												on request							
Open-Chassis (IP00)		Without top and bottom covers												Standard							

		400 V Class																							
Model CIMR-AC4A □□□□		0002	0004	0005	0007	0009	0011	0018	0023	0031	0038	0044	0058	0072	0088	0103	0139	0165	0208	0250	0296	0362	0414	0515	0675
Max. Applicable Motor Capacity [kW]	Normal Duty	0.75	1.5	2.2	3	4.0	5.5	7.5	11	15	18.5	22	30	37	45	55	75	90	110	132	160	185	220	250	355
	Heavy Duty	0.4	0.75	1.5	2.2	3	4.0	5.5	7.5	11	15	18.5	22	30	37	45	55	75	90	110	132	160	185	220	315
Enclosure Panel [NEMA Type1]		Standard												on request											
Open-Chassis (IP00)		Without top and bottom covers												Standard											

Open-Chassis [IP00]

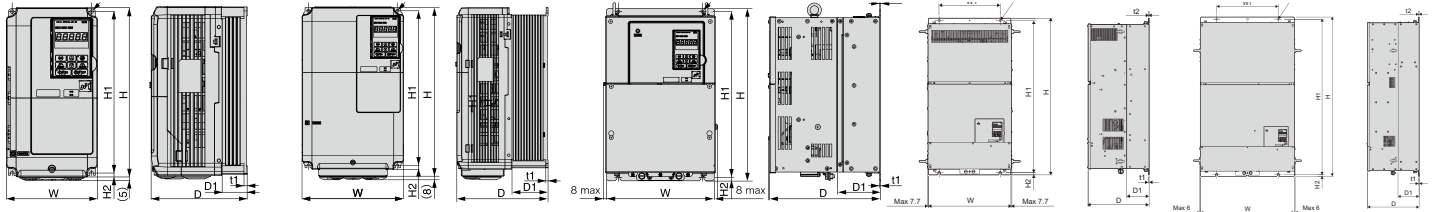

Fig. 1

Fig. 2

Fig. 3

Fig. 4

Fig. 5

200 V Class

Model CIMR-AC2A □□□□	Max. applicable motor capacity [kW]		Figure	Dimensions in mm										Weight (kg)	Cooling	
	Normal Duty	Heavy Duty		W	H	D	W1	H1	H2	D1	t1	t2	d			
0004	0.75	0.4	Fig. 1	140	260	147	122	248	6	38	5	-	4-M5	3.1	Self cooling	
0006	1.1	0.75				164								3.2		
0010	2.2	1.5				167								3.5		
0012	3	2.2				167								4.0		
0021	5.5	4.0	Fig. 2	180	300	187	160	284	8	75	-	-	-	5.6	Fan cooled	
0030	7.5	5.5				197								8.7		
0040	11	7.5				192								9.7		
0056	15	11				335								21		
0069	18.5	15	Fig. 3	220	350	197	192	335	7.5	100	2.3	2.3	4-M6	25	Fan cooled	
0081	22	18.5												220		37
0110	30	22												250		38
0138	37	30												275		38
0169	45	37	Fig. 3	325	550	283	260	535	7.5	110	2.3	2.3	4-M6	37	Fan cooled	
0211	55	45												260		38
0250	75	55												260		76
0312	90	75												260		80
0360	110	90	Fig. 3	450	705	330	325	680	12.5	130	3.2	3.2	4-M10	98	Fan cooled	
0415	110	110												370		102
														773		107
														773		110

400 V Class

Model CIMR-AC4A □□□□	Max. applicable motor capacity [kW]		Figure	Dimensions in mm										Weight (kg)	Cooling	
	Normal Duty	Heavy Duty		W	H	D	W1	H1	H2	D1	t1	t2	d			
0002	0.75	0.4	Fig. 1	140	260	147	122	248	6	38	5	-	4-M5	3.2	Self cooling	
0004	1.5	0.75				164								3.4		
0005	2.2	1.5				164								3.5		
0007	3	2.2				167								3.9		
0009	4.0	3	Fig. 3	180	300	187	160	284	8	75	-	-	-	5.4	Fan cooled	
0011	5.5	4.0				197								5.7		
0018	7.5	5.5				192								8.3		
0023	11	7.5				335								21		
0031	15	11	Fig. 3	220	350	197	192	335	7.5	100	2.3	2.3	4-M6	25	Fan cooled	
0038	18.5	15												220		36
0044	22	18.5												250		41
0058	30	22												275		42
0072	37	30	Fig. 3	325	510	258	260	495	7.5	105	2.3	3.2	4-M6	36	Fan cooled	
0088	45	37												260		41
0103	55	45												260		42
0139	75	55												260		42
0165	90	75	Fig. 3	450	705	330	325	680	12.5	110	3.2	3.2	4-M10	79	Fan cooled	
0208	110	90												325		96
0250	132	110												325		102
0296	160	132												325		102
0362	185	160	Fig. 4	500	800	350	370	773	13	130	4.5	4.5	4-M12	107	Fan cooled	
0414	220	185												773		125
0515	250	220												923		125
0675	355	315												923		221

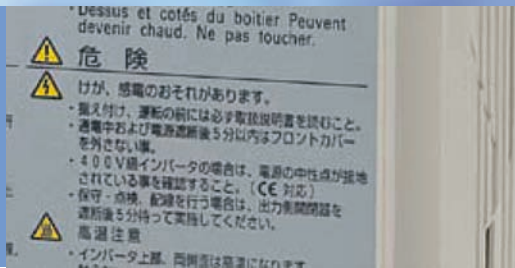

Dimensions

Enclosure Panel [NEMA Type1]

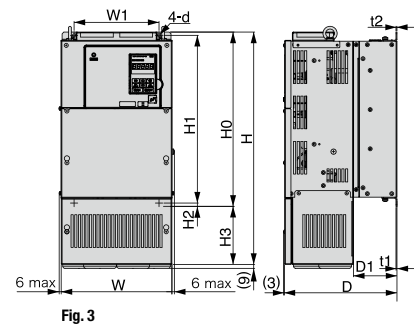
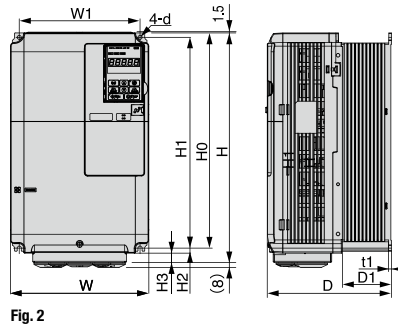
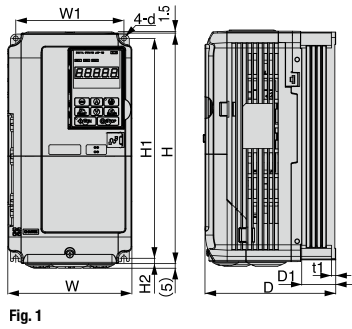

200 V Class

Model CIMR-AC2A □□□□	Max. applicable motor capacity [kW]		Figure	Dimensions in mm												Weight (kg)	Cooling
	Normal Duty	Heavy Duty		W	H	D	W1	H0	H1	H2	H3	D1	t1	t2	d		
0004	0.75	0.4	Fig. 1	140	260	147	122	-	248	6	-	38	5	-	4-M5	3.1	Self cooling
0006	1.1	0.75															
0010	2.2	1.5															
0012	3	2.2				164											
0021	5.5	4.0				167											
0030	7.5	5.5	Fig. 2	180	300	187	160	350	400	385	8	15	75	78	4-M6	5.6	Fan cooled
0056	15	11															
0069	18.5	15															
0081	22	18.5															
0110	30	22				192											
0138	37	30	Fig. 3	254	534	258	195	400	435	7.5	134	100	2.3	2.3	4-M6	23	Fan cooled
0030	7.5	5.5															
0040	11	7.5															
0056	15	11															
0069	18.5	15															
0110	30	22															
0138	37	30															
0169	45	37															
0211	55	45															
0250	75	55															
0312	90	75															
0360	110	90															
				279	614	258	220	450	435	7.5	164	100	2.3	2.3	4-M6	28	Fan cooled
																41	
																42	
																83	
																88	
				504	1168	350	370	800	773	13	368	130	4.5	4.5	4-M12	108	

400 V Class

Model CIMR-AC4A □□□□	Max. applicable motor capacity [kW]		Figure	Dimensions in mm												Weight (kg)	Cooling						
	Normal Duty	Heavy Duty		W	H	D	W1	H0	H1	H2	H3	D1	t1	t2	d								
0002	0.75	0.4	Fig. 1	140	260	147	122	-	248	6	-	38	5	-	4-M5	3.2	Self cooling						
0004	1.5	0.75																					
0005	2.2	1.5																					
0007	3	2.2				164																	
0009	4.0	3				167																	
0011	5.5	4.0	Fig. 2	180	300	187	160	350	400	385	8	15	75	78	4-M6	5.4	Fan cooled						
0004	1.5	0.75																					
0005	2.2	1.5																					
0007	3	2.2																					
0009	4.0	3																					
0011	5.5	4.0																					
0018	7.5	5.5																					
0023	11	7.5																					
0031	15	11																					
0038	18.5	15																					
0044	22	18.5																					
0058	30	22																					
0072	37	30																					
0088	45	37																					
0103	55	45																					
0139	75	55																					
0165	90	75																					
0208	110	90																					
0250	132	110																					
0296	160	132																					
0362	185	160																					
				220	450	435	7.5	65	100	2.3	2.3	4-M6	27	Fan cooled									
																							39
																							45
																							46
																							87
				504	1168	350	370	880	773	13	368	130	4.5	4.5	4-M12	112							



Options

Name	Purpose	Model
Input Noise Filter	Reduces noise from the line that enters into the drive input power system. Should be installed as close as possible to the drive. 400V class: Filter of the manufacturer Block are used. Class C1 and footmounting up to 15 kW (HD), Class C2 and side mounting up to 110 kW (HD)	4A0002 □ AA
		4A0004 □ AA
		4A0005 □ AA
		4A0007 □ AA
		4A0009 □ AA
		4A0011 □ AA
		4A0018 □ AA
		4A0023 □ AA
		4A0031 □ AA
		4A0038 □ AA
		4A0044 □ AA
		4A0058 □ AA
		4A0072 □ AA
4A0088 □ AA		
4A0103 □ AA		
4A0139 □ AA		
4A0165 □ AA		
4A0208 □ AA		
4A0250 □ AA		
AC Chokes	Reducing Harmonics	B06040 Series
Analog input	Enables high-precision and high-resolution analog speed reference setting. • Input signal level: -10 to +10 Vdc (20 kΩ) 4 to 20 mA (500 Ω) • Input channels: 3 channels, DIP switch for input voltage/input current selection • Input resolution: Input voltage 13 bit signed (1/8192) Input current 1/6554	AI-A3
Digital Input	Enables 16-bit digital speed reference setting. • Input signal: 16 bit binary, 2 digit BCD + sign signal + set signal • Input voltage: +24 V (isolated) • Input current: 8 mA Selectable Parameter: 8 bit, 12 bit, 16 bit	DI-A3
DeviceNet communications interface	Used for running or stopping the drive, setting or referencing parameters and monitoring output frequency, output current, or similar items through DeviceNet communication with the host controller	SI-N3
CC-Link communications interface	Used for running or stopping the drive, setting or referencing parameters and monitoring output frequency, output current, or similar items through CC-Link communication with the host controller.	SI-C3
CANopen communications interface	Used for running or stopping the drive, setting or referencing parameters and monitoring output frequency, output current, or similar items through CANopen communication with the host controller.	SI-S3
MECHATROLINK communications interface	Used for running or stopping the drive, setting or referencing parameters and monitoring output frequency, output current, or similar items through MECHATROLINK communication with the host controller.	SI-T3
PROFIBUS-DP communications interface	Used for running or stopping the drive, setting or referencing parameters and monitoring output frequency, output current, or similar items through CANopen communication with the host controller.	SI-P3
Analog monitor	Outputs analog signal for monitoring drive output state (output freq., output current etc.) • Output resolution: 11 bit signed (1/2048) • Output voltage: -10 to +10 Vdc (non-isolated) • Output channels: 2 channels	AO-A3
Digital output	Outputs isolated type digital signal for monitoring drive run state (alarm signal, zero speed detection, etc.). Output channel: Photo coupler 6 channels (48 V, 50 mA or less) Relay contact output 2 channels 250 Vac, 1 A or less 30 Vdc, 1 A or less	DO-A3
Open collector PG interface	For control modes requiring a PG encoder for motor feedback. • Phase A, B, and Z pulse inputs (complementary type) • PG frequency range: Approx. 50 kHz max. • Pulse monitor output: Open collector, max. voltage: 24 V, max. current 30 mA • Power supply output for PG: +12 V, max. current 200 mA	PG-B3
Line Driver PG interface	For control modes requiring a PG encoder for motor feedback. • Phase A, B, and Z pulse (differential pulse) inputs (RS-422) • PG frequency range: up to 300 kHz (approx.) • Pulse monitor output: RS-422 • Power supply output for PG: +5 V or +12 V, max. current 200 mA	PG-X3
LED Operator	Easy long distance reading	JVOP-182
Braking Resistor	Used to shorten the deceleration time by dissipating regenerative energy through a resistor. (3% ED) (all models up to 3,7 kW)	ERF-150WJ series
Braking Chopper Unit	Shortened deceleration time results when used with a Braking Transistor Unit.	CDBR series
24 V Power Supply	Provides power supply for the control circuit and option boards. Note: Parameter settings cannot be changed when the drive is operating solely from this power supply.	PS-A10H PS-A10L
USB Copy Unit (RJ-45/USB compatible plug)	• Adapter for connecting the drive to the USB port of a PC • Can copy parameter settings easily and quickly to be later transferred to another drive.	JVOP-181
LCD operator extension cable	Cable for connecting the LCD operator.	WV001: 1 m WV003: 3 m

Note: contact the manufacturer in question for availability and specifications of non-YASKAWA products.



Ratings & Type Descriptions

Model Number Key

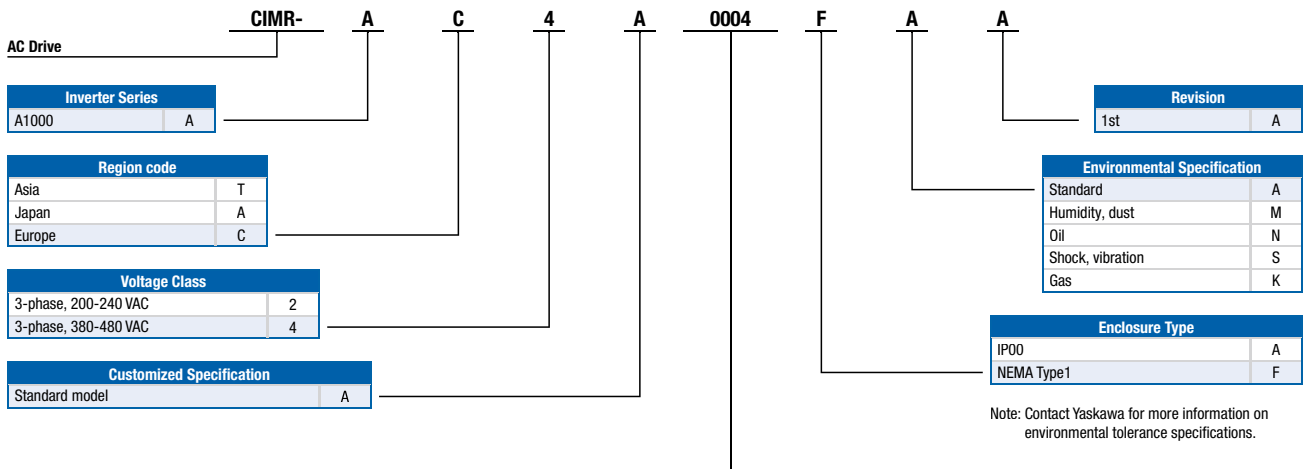

200 V				
	Normal duty*1		Heavy duty	
	Rated output current [A]	Max. applicable motor*2 [kW]	Rated output current [A]	Max. applicable motor*2 [kW]
0004	3.5	0.75	3.2*3	0.4
0006	6	1.1	5*3	0.75
0010	9.6	2.2	8*3	1.5
0012	12	3	11*3	2.2
0021	21	5.5	17.5*3	4.0
0030	30	7.5	25*3	5.5
0040	40	11	33*3	7.5
0056	56	15	47*3	11
0069	69	18.5	60*3	15
0081	81	22	75*3	18.5
0110	110	30	85*3	22
0138	138	37	115*3	30
0169	169	45	145*4	37
0211	211	55	180*4	45
0250	250	75	215*4	55
0312	312	90	283*4	75
0360	360	110	346*4	90
0415	415	110	415*1	110

400 V				
	Normal duty*1		Heavy duty	
	Rated output current [A]	Max. applicable motor*2 [kW]	Rated output current [A]	Max. applicable motor*2 [kW]
0002	2.1	0.75	1.8*3	0.4
0004	4.1	1.5	3.4*3	0.75
0005	5.4	2.2	4.8*3	1.5
0007	6.9	3	5.5*3	2.2
0009	8.8	4.0	7.2*3	3
0011	11.1	5.5	9.2*3	4.0
0018	17.5	7.5	14.8*3	5.5
0023	23	11	18*3	7.5
0031	31	15	24*3	11
0038	38	18.5	31*3	15
0044	44	22	39*3	18.5
0058	58	30	45*3	22
0072	72	37	60*3	30
0088	88	45	75*3	37
0103	103	55	91*3	45
0139	139	75	112*4	55
0165	165	90	150*4	75
0208	208	110	180*4	90
0250	250	132	216*4	110
0296	296	160	260*4	132
0362	362	185	304*4	160
0414	414	220	370*4	185
0515	515	250	450*1	220
0675	675	355	605*1	315

*1: This value assumes a carrier frequency of 2 kHz. Increasing the carrier frequency requires a reduction in current.
 *2: The motor capacity (kW) refers to a Yaskawa 4-pole, 60 Hz, 200 V motor or 400 V motor. The rated output current of the drive output amps should be equal to or greater than the motor rated current.
 *3: This value assumes a maximum carrier frequency of 8 kHz. Increasing the carrier frequency requires a reduction in current.
 *4: This value assumes a maximum carrier frequency of 5 kHz. Increasing the carrier frequency requires a reduction in current.



YASKAWA Electric Europe GmbH

Hauptstr. 185
65760 Eschborn
Deutschland / Germany

+49 6196 569-300
info@yaskawa.de
www.yaskawa.eu.com

International Standards



Safety Standards

Safety Stop

RoHS Directive

RoHS Directive stands for the EU directive on the Restriction of the Use of Certain Hazardous Substances in Electrical and Electronic Equipment